

THINK

DESK

Concept and Modularity

Desk Master

Designed as a working desk.

Work with simultaneously with
Tinting and Master System.

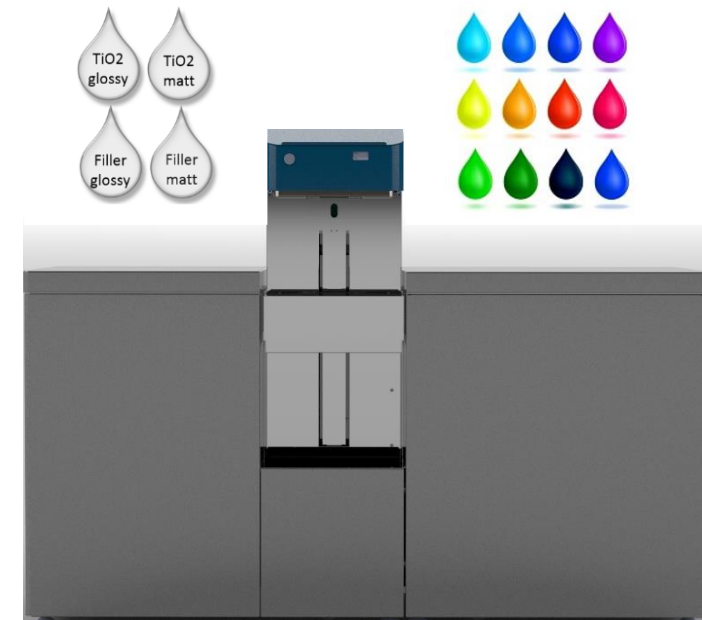
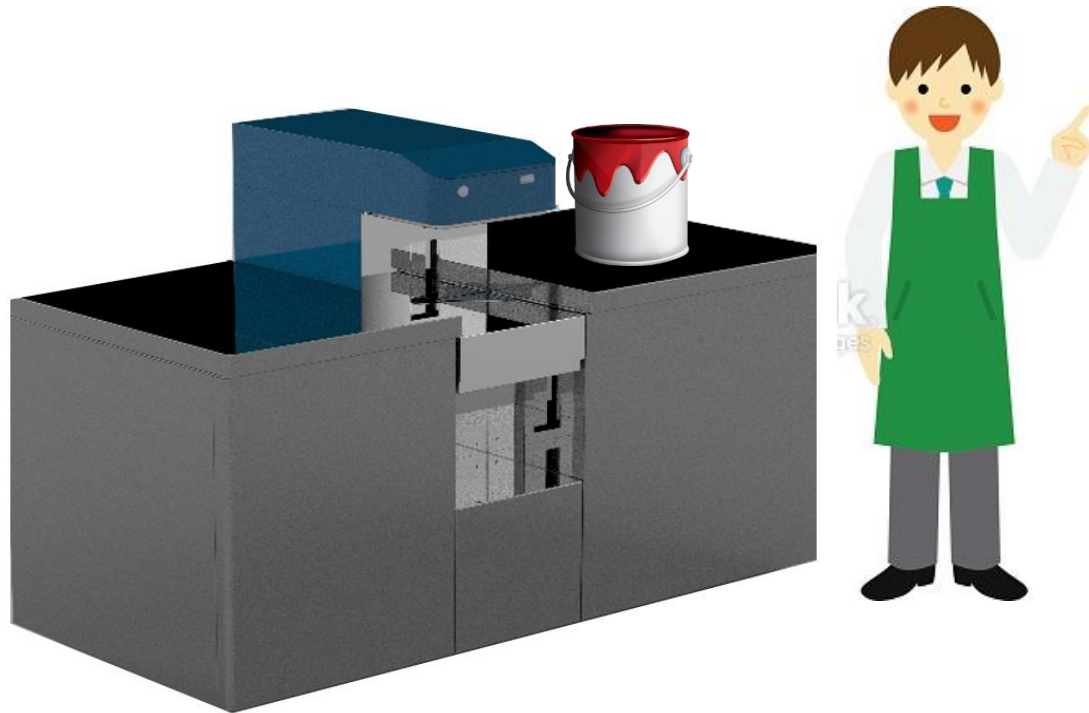

Available with up to 24 colorants.

Desk Tinting



Available with up to 24 colorants.

Modularity

STEP 1

Install Desk Tinting in your new POS and for the substitution program.



STEP 2

Once you are ready with the Master System, you simply attach the Master Module.

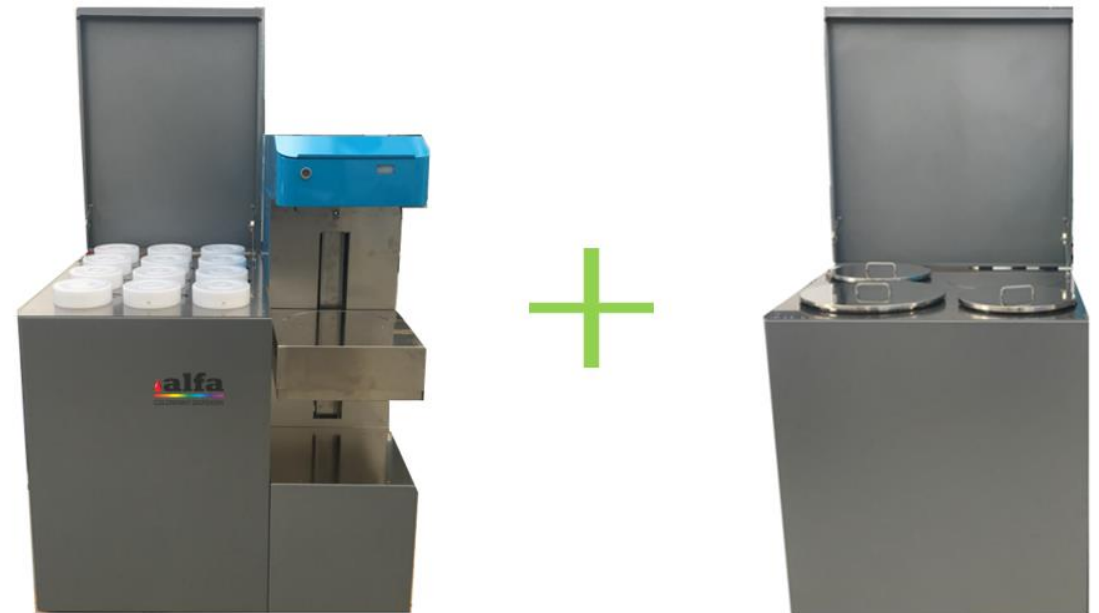

Master Module Head



Desk Master



Modularity

STEP 1

Install a Master Module Head next to your current tinting machine.



STEP 2

Once the tinting machine has finished its lifecycle, you attach the Colorants Module.

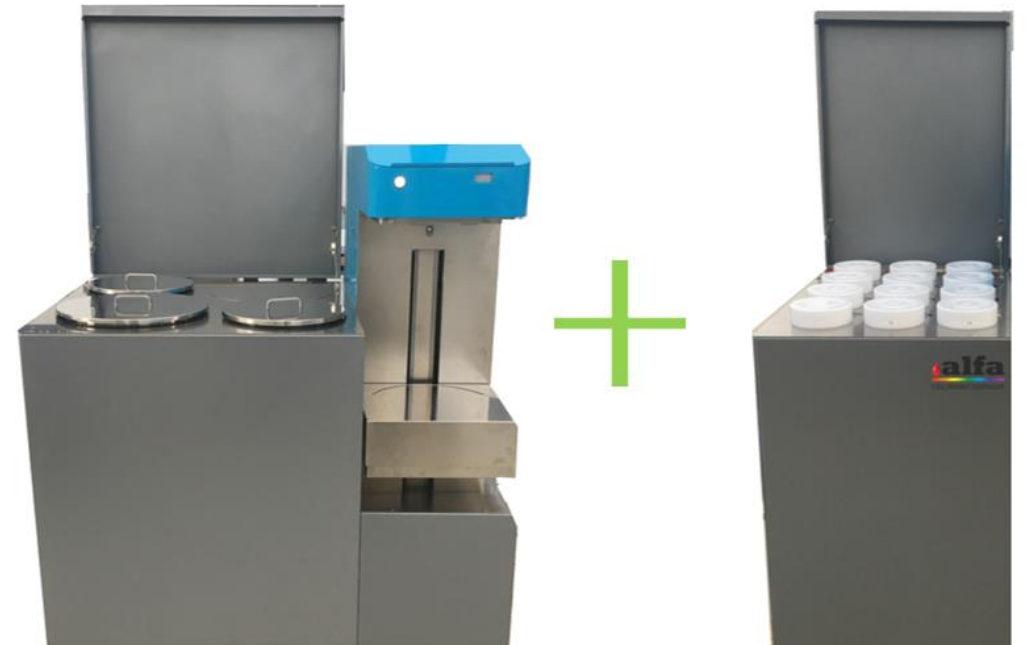

Dispensing Head Features

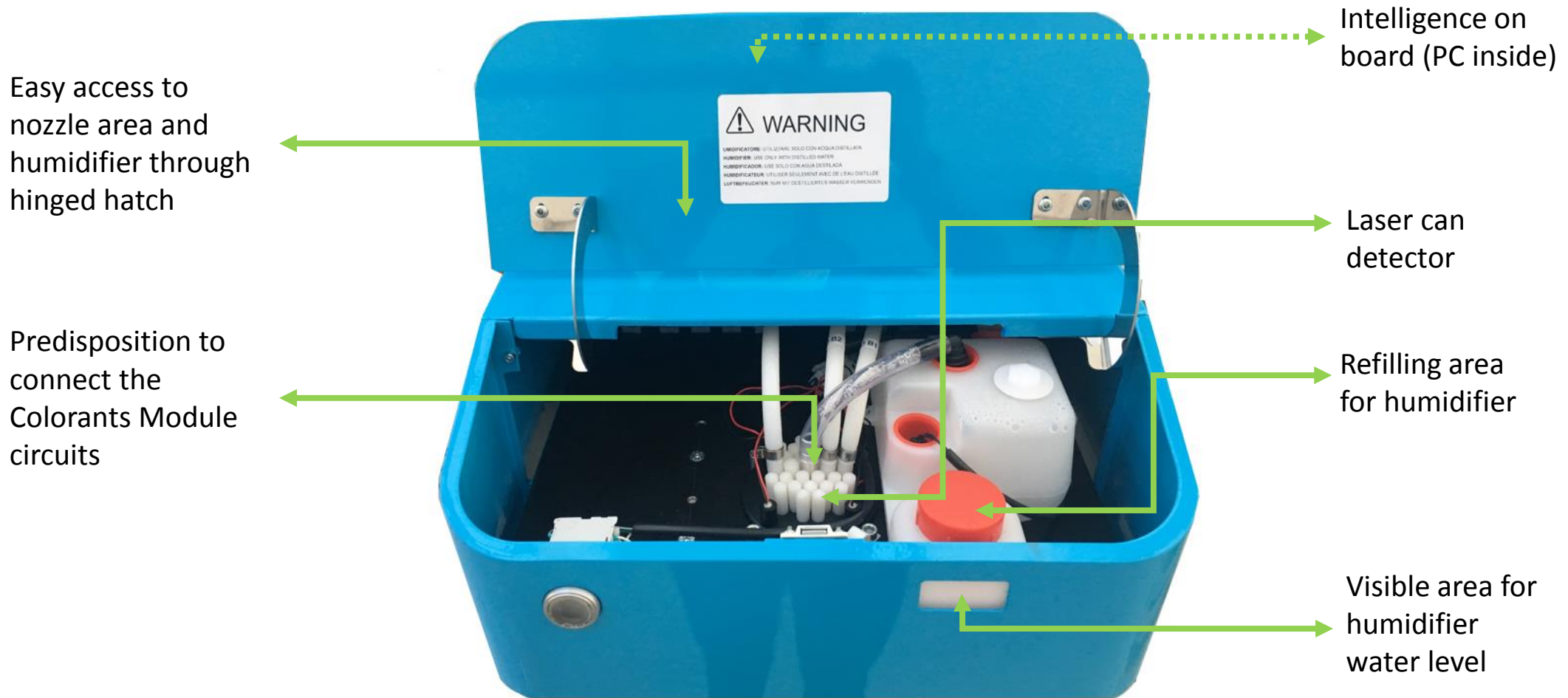

DESK

Configurations

Configuration Desk Tinting

DESK TINTING 12



104cm length

DESK TINTING 16

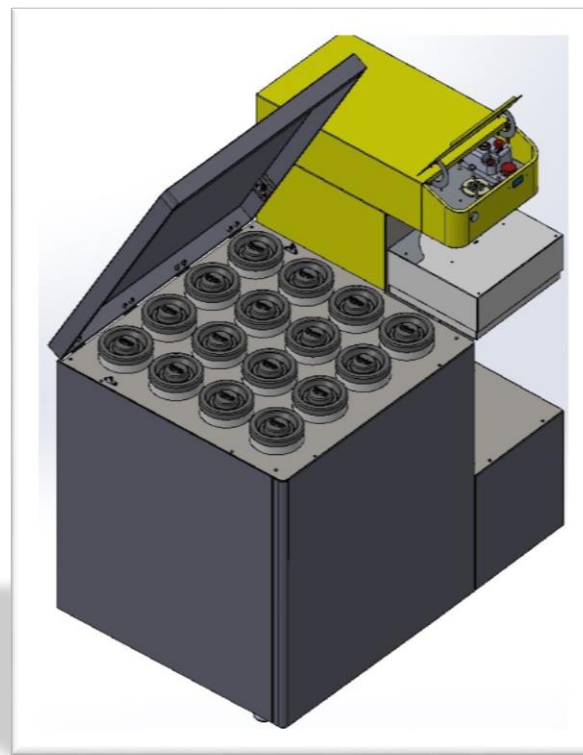

124cm length

DESK TINTING 24

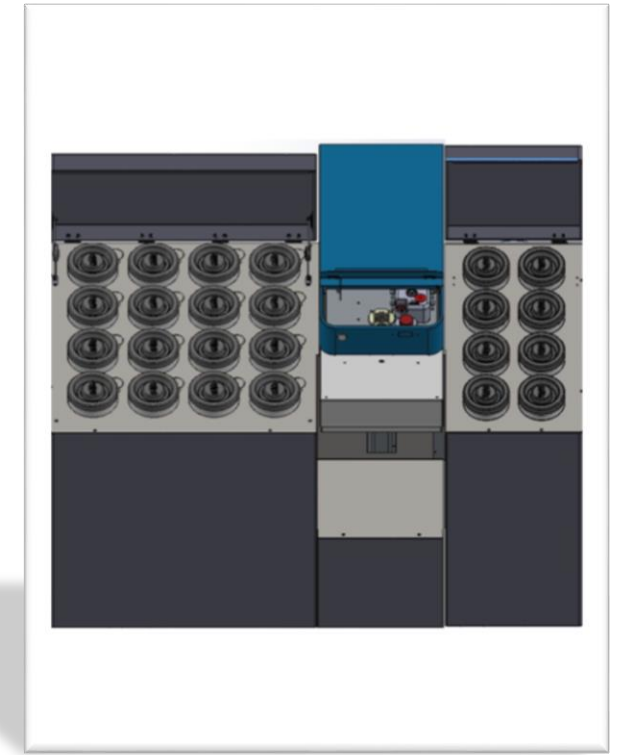

174cm length

Configuration Master Module

MASTER MODULE LP

UP TO 4 SEMI-FINISHED PRODUCTS
=> 2 x 35 Lt canisters
=> 2 x 6 Lt canisters

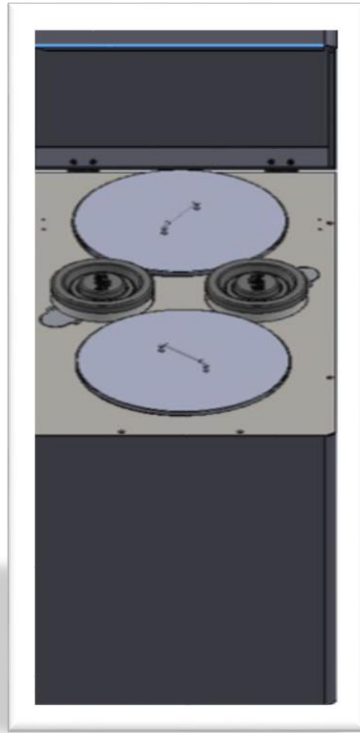

50cm lenght

MASTER MODULE HP

UP TO 4 SEMI-FINISHED PRODUCTS
=> 2 x 55 Lt canisters
=> 2 x 35 Lt canisters

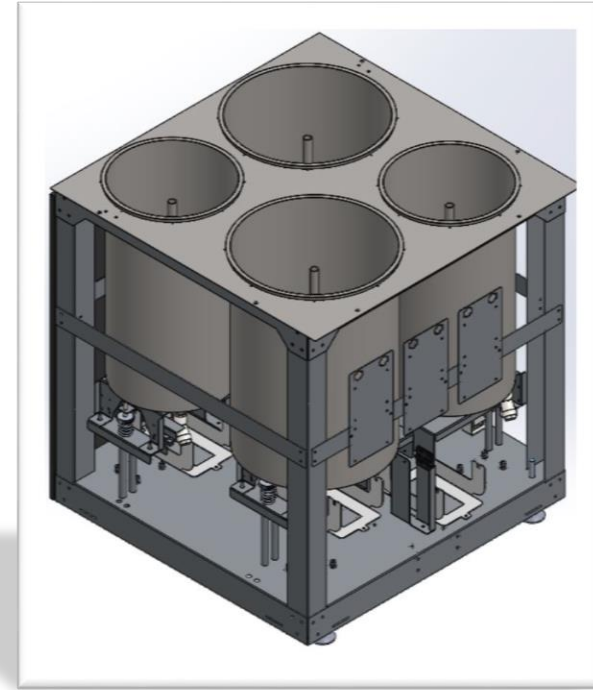

84cm lenght

Configuration Desk Master

DESK MASTER 16

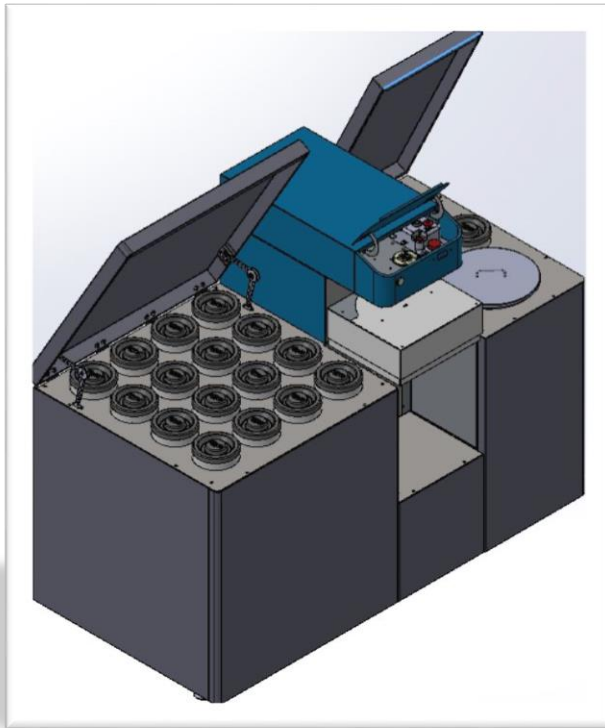

174cm length

DESK MASTER 24



224cm length

Available also in the version 12 and 20 colorants

Technical Data

FEATURES

- Simultaneous dispensing flow.
- Up to 24 colorants / 4 semifinished products.
- Pumps 0.2-0.4 lt/min for colorants.
- Pump 2 lt/min for semifinished products.
- Semifinished products level digital sensor.
- Internal router suitable for local SIM card

OPTIONS

- Dispensing head custom colors (RAL).
- Automatic shelf.
- Humidifier
- Laser to locate centre of lids
- Upgrade for solvent products compatibility



DESK

Innovations

New Patented Pumps

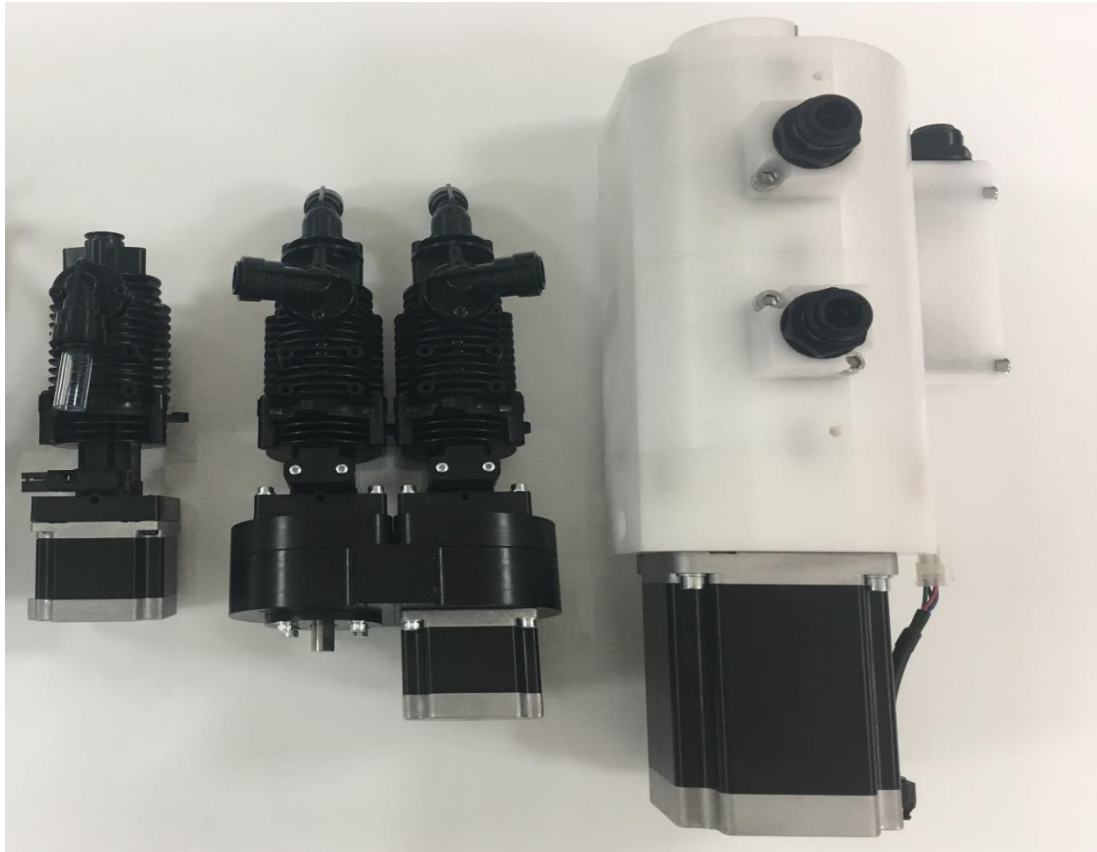

- No more calibration adjustments, just first set-up.
- Purge air before dispensing.
- Dispense VOC FREE, water and solvent (products to be tested) based products.
- 3 years warranty on critical pump components.

Pumps Scalability

Pump 0.2 lt/min
Minimum drop 0.038cc

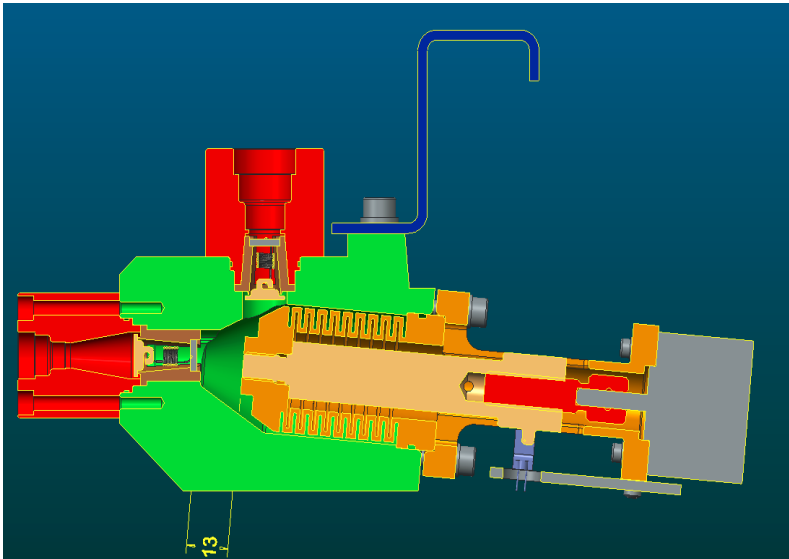

Pump 0.4 lt/min
Minimum drop 0.038cc

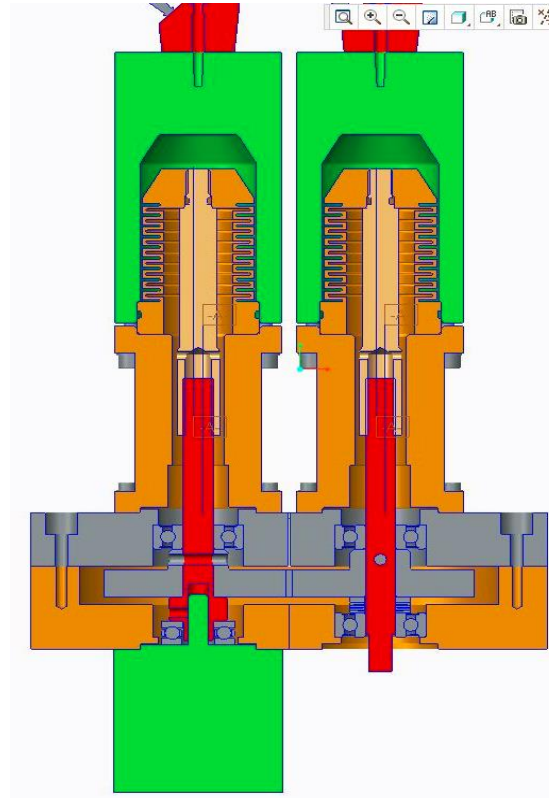

Pump 2 lt/min
Minimum drop 0.4cc

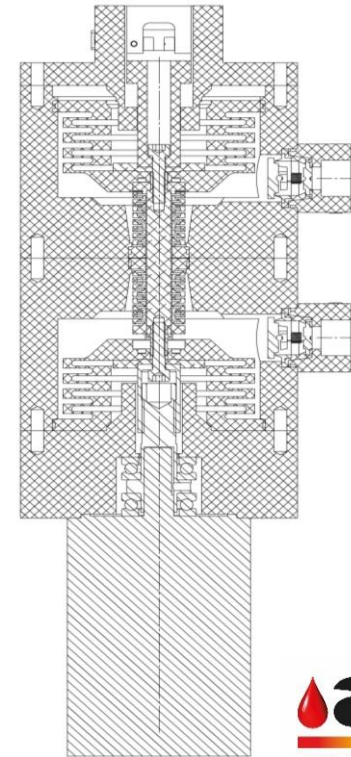

Humidifier

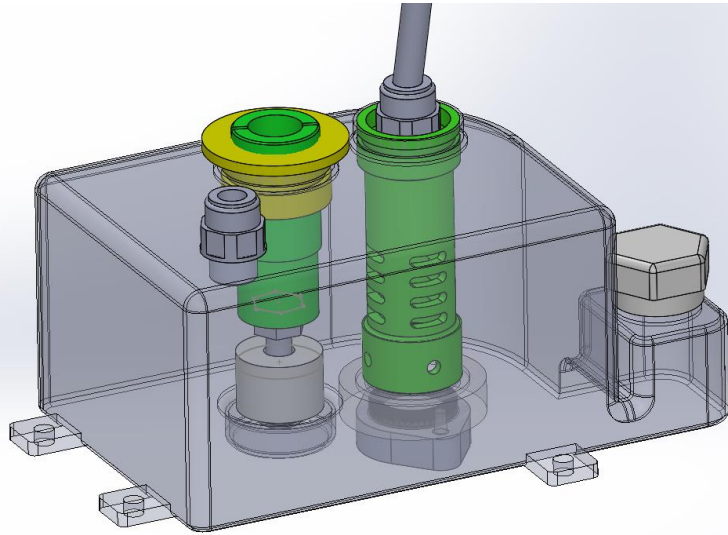

Ultrasonic nebulizer, a device that causes vaporization of water molecules by vibration of a metal sheet and keeps the water bacteria-free. The water reserve level can also be checked from remote.

From Automatic to Smart Unit

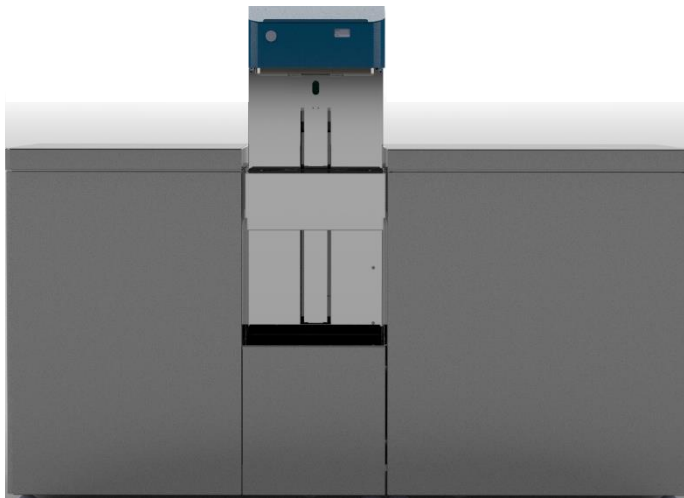

Intelligence on board,
independent from store PC
and software.

No need for a PC, any
device with a browser can
operate the unit.

Direct control on your technology

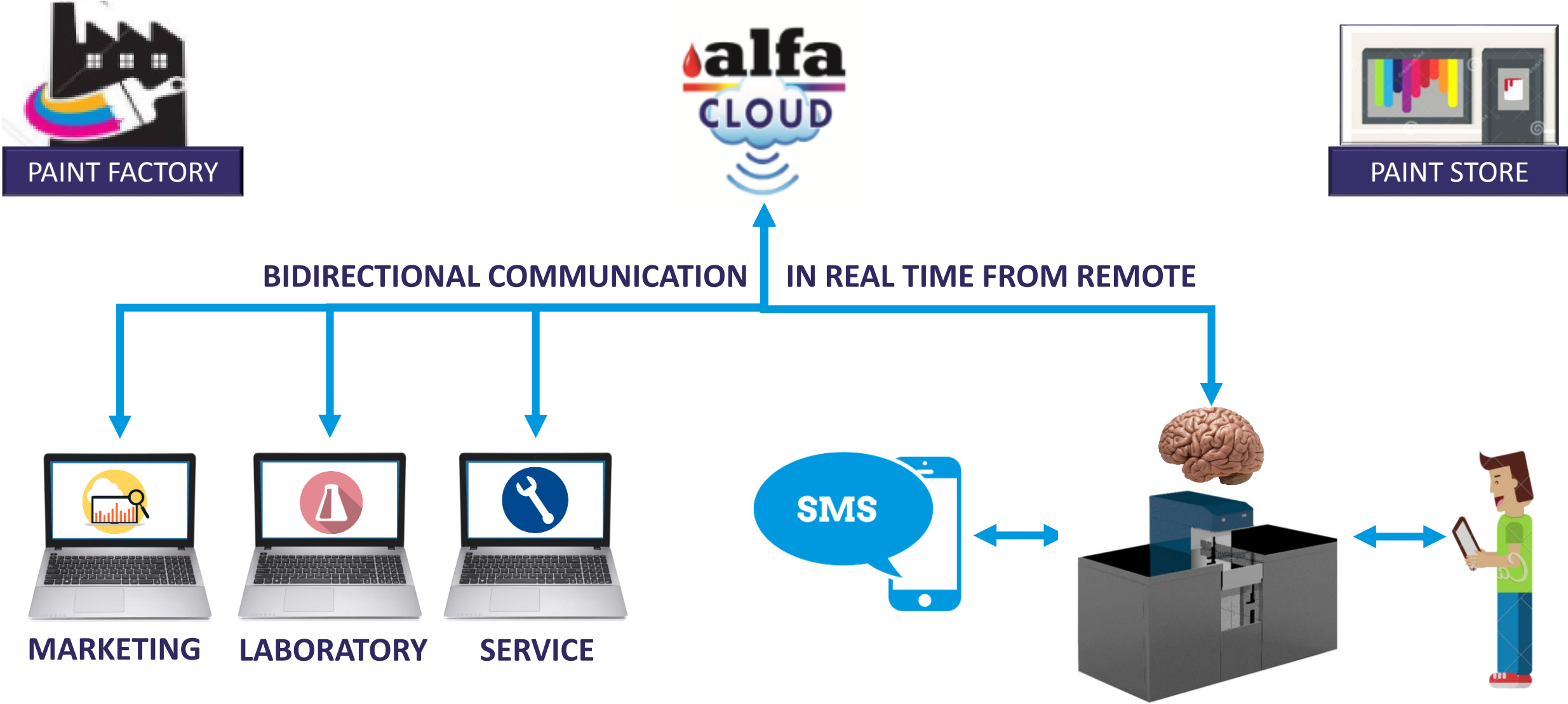

DESK

Total Cost of Ownership

Desk vs. third party dispensers

	Alfa Desk	Third party dispensers
Pump precision / repeatability	●	●
Machine maintenance	●	● / ●
On board intelligence and connectivity	●	●
Ergonomic	●	● / ●
Dispensing flow (seq. or sim.)	●	● / ●
Spare parts optimization	●	●
Predisposed for Master System	●	●
Dimensions	●	● / ●
Working space optimization	●	●
Price	●	● / ●
Total cost of ownership	●	●

Alfa Relax

Alfa Relax guarantees a complete warranty of Alfa's production components and all the assistance and remote corrective maintenance for first support activities.

The service will be provided via remote assistance with Internet using Alfa Cloud and possibly through the support of visual communication tools (eg. web-cam) in necessary cases.



Lower Total Cost of Ownership

PUMP

- 3 years warranty on critical pump components. ---
- No more calibration adjustments needed, only initial set-up. - xx €/year
- Remote modification of pumps parameters. - xx €/year
- Independent pump groups to reduce service time. - xx €/year
- Pump accuracy and repeatability to reduce complaints. - xx €/year

SOFTWARE

- Easier maintenance and service from remote to reduce downtime. - xx €/year
- Assist store with troubleshooting in real time from remote . - xx €/year
- Upload and download formulas from remote. - xx €/year
- Upgrade and downgrade software and firmware from remote. - xx €/year
- Statistics in real time and increased point of sales control. - xx €/year

TECHN. DATA

- Innovative ecological humidifying system. - xx €/year
- PC not necessary. - 400 €
- Spare parts standardization. - xx €/year

Thank you!

