

Technical Manual

Mini Mixer



ORIGINAL INSTRUCTION

Code:	
-------	--

Year:	2016
-------	------

Rev.:	02
-------	----

Alfa Srl
Via Caduti di Ustica, 28 - Calderara di Reno
40012 BOLOGNA – Italy
Tel +39 051 0828494 Fax +39 051 0824283

© Copyright 2015 Tutti i diritti riservati

© Copyright 2015 All rights reserved

Total or partial reproduction, modification and translation of the present manual is forbidden without previous authorisation of **Alfa Srl**.

IMPORTANT:

Alfa Srl will be not liable for technical or editorial errors or omissions contained herein

IMPORTANT:

Alfa Srl cannot be held responsible for any errors or damage caused by the use of supplies or spare parts not specifically approved or guaranteed by **Alfa Srl**.

Table of contents

0. FOREWORD	6
0.1. HOW TO USE THE MANUAL	6
0.1.1. IMPORTANCE OF THE MANUAL	6
0.1.2. HOW TO KEEP THE MANUAL	6
0.1.3. HOW TO CONSULT THE MANUAL	6
0.1.4. SYMBOLS USED IN THE MANUAL	7
0.1.5. PROCEDURE FOR UPDATING THE MANUAL IN CASE OF MODIFICATIONS TO MACHINE	7
0.2. SAFETY INFORMATION	8
0.2.1. PRECAUTIONS AND USAGE REGULATIONS	8
0.2.2. GENERAL SAFETY WARNINGS	8
0.2.3. USERS AND ACCESS LEVELS	9
0.2.4. RESIDUAL RISKS AND DANGEROUS AREAS	9
0.2.5. CONTACT WITH COLORANT PRODUCTS	10
0.2.5.1. GENERAL FIRST AID MEASURES	10
0.3. TECHNICAL SPECIFICATIONS	10
0.3.1. ELECTRICAL SPECIFICATIONS	10
0.3.2. EQUIPMENT CLASSIFICATION AND REFERENCE STANDARDS	10
0.3.3. OPERATING CONDITIONS	11
0.3.4. DIMENSIONS AND WEIGHT	11
1. DESCRIPTION OF THE MACHINE	12
1.1. MAIN COMPONENTS	12
1.1.1. PROTECTIONS AND GUARDS	12
1.1.2. ELECTRICAL CONTROL PANEL	12
2. PARTS REMOVAL AND REPLACEMENT	13
2.0. SAFETY REGULATIONS ON MAINTENANCE	13
2.0.1. AUTHORISED PERSONNEL	13
2.0.2. MACHINE SWITCHING OFF	13
2.0.3. ACCESS TO THE REPAIR OPERATIONS	13
2.0.4. MACHINE RESTORATION AND START AFTER THE INTERVENTION	13
2.0.5. CHECKING THE OPERATION OF THE SAFETY DEVICES	13
2.0.6. WORK EQUIPMENT	14
2.0.7. PRODUCT DISPOSAL	14
2.1. EXTERNAL PANEL REMOVAL	15
2.1.1. FRONT PANEL REMOVAL	15
2.1.2. REAR PANEL REMOVAL	16
2.2. BELT AND STIRRING UNIT REPLACEMENT	17
2.3. REMOVAL OF THE STAINLESS STEEL INTERNAL PROTECTION PLATE	18
2.4. DC MOTOR AND/OR BEARINGS REPLACEMENT	18
2.5. VIBRATION DAMPER REPLACEMENT	19
3. ELECTRIC REPAIRING OPERATIONS	20
3.1. DIAGNOSIS AND ELECTRONIC PART DESCRIPTION	20
3.1.1. SCCB BOARD	20
3.2. CHECKING AND REPLACING THE NETWORK FUSES	20
3.3. REPLACEMENT OF ELECTRIC PARTS	21
3.3.1. DESCRIPTION OF ELECTRIC PARTS	21
3.3.2. REPLACING THE POWER SUPPLY UNIT	21
3.3.3. SCCB CONTROL BOARD REPLACEMENT	22
3.3.4. RELAY AND BRAKING RESISTANCE REPLACEMENT	22
3.3.5. MOTOR PROTECTION FUSE REPLACEMENT	22

4. PROGRAMMING THE ELECTRONIC BOARDS	23
4.1. PROGRAMMING DEVICES	23
4.2. INSTALLING THE MPLAB IDE SOFTWARE	23
4.3. PROGRAMMING WORKSPACE	23
4.4. PROGRAMMING THE SCCB BOARD	23
4.4.1. FIRMWARE AND WORKSPACE DOWNLOAD	23
4.4.2. PROGRAMMING THE MINI MIXER SCCB BOARD	24
5. PROGRAMMING STIRRING TIME	26
5.1. PROGRAMMING INPUT	26
6. MECHANICAL DRAWINGS AND SPARE PARTS LIST	27
7. CONNECTION DIAGRAMS	31

Page left intentionally blank

0. FOREWORD

0.1. HOW TO USE THE MANUAL

0.1.1. IMPORTANCE OF THE MANUAL

This manual provides instructions on the ordinary and extraordinary maintenance of MINI MIXER.

Further ordinary maintenance instructions are provided in the Operator Manual.

Before performing any repair or extraordinary maintenance operation, carefully read this manual in all its parts and in particular the chapters "GENERAL INFORMATION", "INSTALLATION" and "HOW TO PRODUCE A SAMPLE", paying more attention to the paragraphs related to precautions and safety alerts.

In case problems or difficulties should arise, the TECHNICAL SERVICE SUPPORT of Alfa Srl is always available to provide the right support, advice, explanation and assistance.

Alfa Srl reserves the right to make modifications for improving its own products without prior notification.

The incorrect use of the system can lead to loss of warranty in all its forms and terms.

0.1.2. HOW TO KEEP THE MANUAL

Do not remove, modify, rewrite contents of this manual for any reason.

Keep the manual in a safe place, protected from heat and humidity.

0.1.3. HOW TO CONSULT THE MANUAL

This manual comprises:

- COVER PAGE IDENTIFYING THE TYPE OF PRODUCT
- TABLE OF CONTENTS
- INSTRUCTIONS AND/OR NOTES ON THE PRODUCT

The COVER PAGE identifies the product described in this manual.

Use the CONTENTS to find the list of CHAPTERS and PARAGRAPHS contained in the manual and their subjects.





The INSTRUCTIONS AND/OR NOTES ON THE PRODUCT define the safe working practices and advice on the correct procedures and the skills required to correctly operate and maintain the system.

Some images of this manual having been enclosed for easier identification of the described parts may not be exactly the same as the ones in your System.

0.1.4. SYMBOLS USED IN THE MANUAL

The safety and advice symbols used in this manual are used to draw the reader's attention to warnings concerning safety or indicating good working practices.
The same symbols are also placed on the machine to indicate dangerous areas and refer to the relevant safety notes in the manual.

MEANING OF THE SYMBOLS

	WARNING! GENERAL DANGER
	WARNING! HIGH VOLTAGE
	WARNING! RISK OF CRUSHING.
	GROUND CABLES THIS SYMBOL INDICATES GROUND REFERENCE POINT.



0.1.5. PROCEDURE FOR UPDATING THE MANUAL IN CASE OF MODIFICATIONS TO MACHINE

If the MACHINE or MANUAL is MODIFIED in any way, an UPDATE could be sent for insertion into the printed Manual.







0.2. SAFETY INFORMATION

0.2.1. PRECAUTIONS AND USAGE REGULATIONS

The machine must be positioned in an enclosed area that complies with the environmental requirements set out in the relevant paragraph.

	<p>Do not install the machine in a dusty environment. Do not expose the machine to sources of heat, excessive cold, water, electromagnetic energy, or sources of smoke. The machine must be positioned on perfectly level flooring.</p>
	<p>Always make sure that the power cable is intact and free of any cuts or cracks. In case of cable damage, renew the cable using genuine spare parts.</p>
	<p>The noise level generated by the machine is less than 70 DB (measured at a distance of 1 m and at a height of 1.60 m from the floor). This value can be exceeded in certain work environments. If the noise to which the operator is exposed on a daily basis is presumably greater than 85 DB, effective hearing protections must be used, as required by the 86/188/EEC regulations.</p>

0.2.2. GENERAL SAFETY WARNINGS

	<p>MINI MIXER is compliant with all the safety requirements of the main European and extra-European Standards and Institutions. Despite that, it is suggested to read carefully the information contained in this chapter and in the next pages since they show the possible dangerous situations and the necessary precautions to take.</p>
	<p>The machine is provided with doors and guards that prevent the operator from getting in contact with mechanical and electrical hazardous parts. A periodical check on the safety devices must be performed according to the instructions provided by this manual. If the safety protection systems are damaged, turn off the machine and call the technical service.</p>
	<p>High voltage parts - Risk of electric shock No high voltage part is accessible from the User area. All the high voltage circuits are contained into enclosed areas and protected by fixed guards. The high-voltage internal parts are accessible to the maintenance operator and are protected against direct contact with dangerous parts by means of IP 2X or higher class protection. Dangerous parts are marked by the symbol indicated on the side.</p>
	<p>Dangerous mechanical parts - Risk of crushing or trapping. Internal moving parts are accessible only to technical personnel. Do not put your hands into the machine working areas. Tie hair to avoid the risk that it can be trapped in the machine. For the same reason, keep away of the machine or avoid wearing any hanging objects such as ties, necklaces, pendants or other similar items.</p>
	<p>High-temperature parts - Risk of scalds The machine includes no components or areas that may reach so high temperature as to become dangerous for the user, the maintenance operator or the technician. The areas where this risk can occur, under faulty conditions, are marked by the symbol indicated on the side.</p>
	<p>Flammable parts - Risk of fire The machine is made from materials which do not propagate fire in order to minimise fire risk. Nevertheless, the machine must be installed in a duly ventilated room, complying with the manufacturer's installation requirements. Never leave materials, fluid or foreign objects that might increase the risk and spread of a fire inside the machine.</p>
	<p>It is forbidden to modify the machine's internal an external protections. Contact Alfa's Technical Support Service if necessary. Alfa Srl shall bear no responsibility for any damage that may arise due to the failure to comply with the above instructions. In the event of a malfunction, contact the manufacturer's technical support service.</p>



GROUND CONNECTION

Ground wire connection point.

Always ensure that yellow-green ground leads are duly fastened to the ground point indicated by the symbol on the side.

DO NOT REMOVE GROUND CONNECTIONS.

In case of lead damage, switch machine off and immediately contact the technical service support.

IF THE EQUIPMENT HAS BEEN USED IN A MANNER NOT SPECIFIED BY THE MANUFACTURER, THE PROTECTION PROVIDED BY THE EQUIPMENT MAY BE IMPAIRED

0.2.3. USERS AND ACCESS LEVELS

The machine has three different user levels:

- **USER:** an operator who uses the machine to mix colour samples;
- **MAINTENANCE OPERATOR:** user in charge of performing ordinary maintenance operations, such as machine cleaning and check of safety sensors;
- **TECHNICIAN:** expert and authorised user who operates for troubleshooting and extraordinary maintenance operations.
- **ADMINISTRATOR:** a superuser who's authorised to access the machine's software in order to add or delete users, change user rights, reset passwords, etc.

In order to identify the various areas of intervention, the following definitions must be taken into account:

- **USER AREA:** machine area that the user accesses in order to produce a colour sample. It includes controls for switching equipment on and off, and the internal parts to position and remove the sample;
- **MAINTENANCE OPERATOR AREA:** internal area of the machine that can be accessed by opening mobile doors that may require the use of a key. It corresponds to the areas where ordinary maintenance operations can be performed (stirring compartment cleaning);
- **SERVICE AREA (FOR USE BY TECHNICIANS):** the internal areas of the machine that can not be accessed using a single key, but whose access also requires the use of other tools (e.g. parts inside fixed protections, such as driving belt, motor and relevant organs, electric parts);

0.2.4. RESIDUAL RISKS AND DANGEROUS AREAS

USER: The machine does not present any risk for the operator.

MAINTENANCE OPERATOR: The door allowing access to machine internal parts is controlled by safety interlock micro-switches which stop any movement if doors are opened during machine operation.

The following are potentially dangerous areas in case the door is opened:

- can stirring area: risk of crushing.

TECHNICIAN: The authorised technician is authorised to remove covers to do extraordinary maintenance work and repairs, also when micro-switches are disabled. In these circumstances there is a risk of coming into contact with dangerous moving parts:

- rotating unit: risk of injury by impact with rotating part; arm, hands, fingers, hair or clothes trapping risk caused by rotating movement of the unit.
- Drive belt: crushing or trapping risk for hands or fingers from belt movement;
- Electric parts: risk of electric shock due to contact with dangerous voltage circuits (mains filter, power supply unit).

Any intervention that requires the operator to access zones where risks of electric shock are present must be performed with the machine off.

0.2.5. CONTACT WITH COLORANT PRODUCTS

Beware of colorant leaks, before, during and after sample stirring.

Contact with water-based paints can cause irritations or injuries if not properly treated.

In case of need always refer to the safety sheet of the concerned liquid, available at the colorant manufacturer.

0.2.5.1. GENERAL FIRST AID MEASURES

In the event of eye contact: remove contact lenses, if present. Immediately rinse the eyes with running water for at least 15 minutes, holding the eyelids open. Consult a physician immediately.

In the case of skin contact: remove the contaminated garments. Wash the skin thoroughly with soap and water.

Ingestion: immediately consult a physician and show them the can, label or material safety data sheet. Keep the person warm and relaxed. Do not induce vomiting.

0.3. TECHNICAL SPECIFICATIONS

0.3.1. ELECTRICAL SPECIFICATIONS

Power supply	100-240Vac 50-60Hz
Max current	1.2±0.5A
Absorbed power	120W max
Fuses 5X20 mm	T1.6A-250V Q.ty 2pcs
Working noise (*)	Lower than 70 dB (A)

(*) A-weighted sound pressure level determined during normal use to 1 m distance far from the surface of the machinery and to 1.60 m height from the floor.

0.3.2. EQUIPMENT CLASSIFICATION AND REFERENCE STANDARDS

Overvoltage category	II See note (1)
Protection classification	IP 20
Class of equipment	I
Reference standards	UNI EN ISO 12100 IEC EN 60335-1 IEC EN 60204-1 IEC EN 55022 IEC EN 55024 IEC EN 61000-3-2 IEC EN 61000-3-3 UL 1450
Airborne noise (*)	Lower than 70 dB (A)

Note (1):

The equipment is protected for overvoltage up to 1500V. For power lines subjected to transients with peaks of voltage greater than 1500V, the use of external suitable protection devices is recommended.

0.3.3. OPERATING CONDITIONS

Operating temperature (*)	+5 ÷ +35°C
Relative humidity	30% ÷ 90% without condensate
Storage temperature	-25 ÷ +55°C
Altitude	2000 m

0.3.4. DIMENSIONS AND WEIGHT

Height	450 mm (±15mm)
Width	480 mm
Depth	480 mm
Weight (empty)	Kg 60

1. DESCRIPTION OF THE MACHINE

1.1. MAIN COMPONENTS

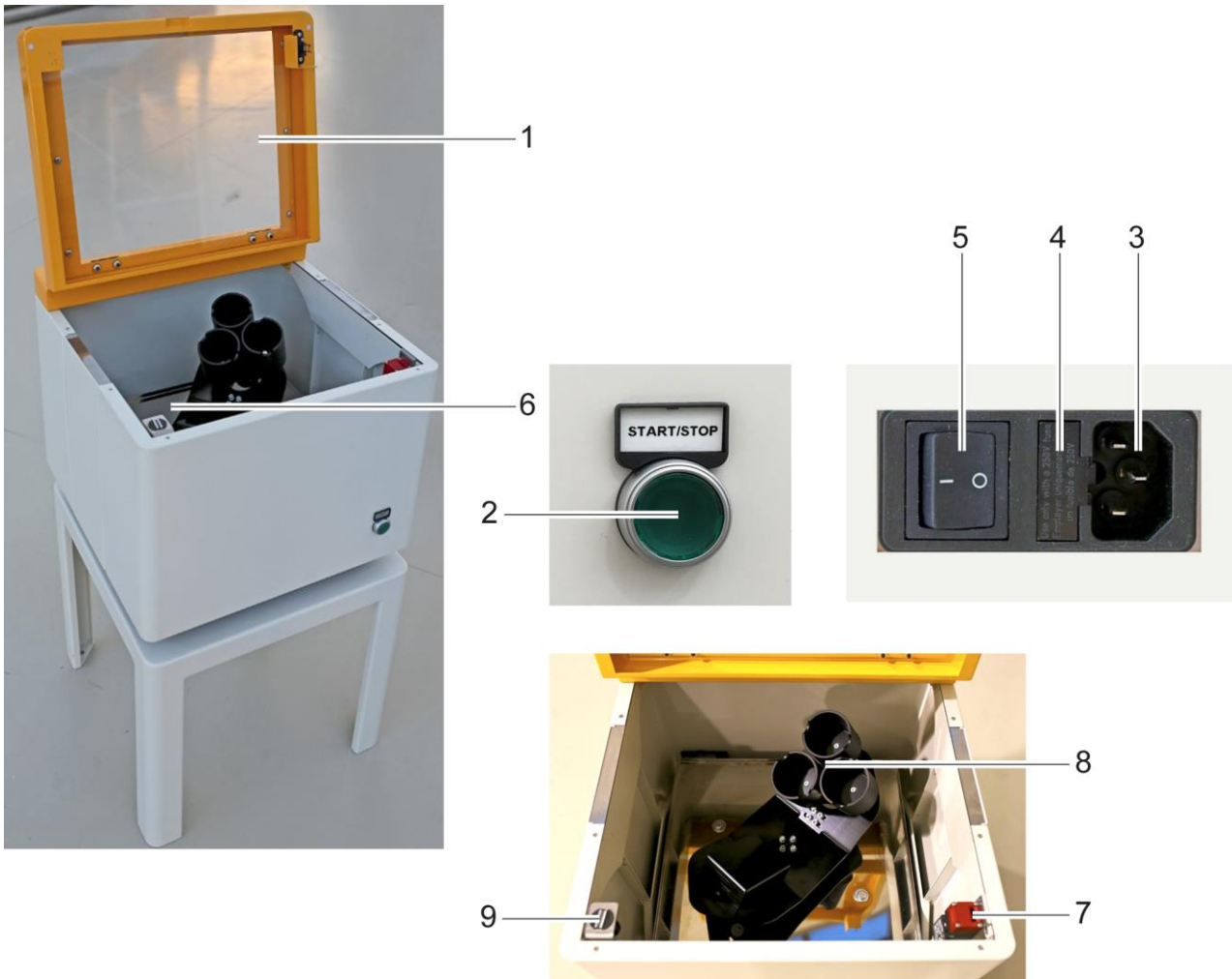

1.	Opening door	2.	START/STOP button
3.	mains connection socket	4.	protection fuse
5.	On/off switch	6.	support cabinet (optional)
7.	Safety sensor	8.	Colour samples supports
9.	Magnet for door closing		

1.1.1. PROTECTIONS AND GUARDS

Mixer protections consist of:

1. Opening door;
2. Rear panel;
3. Internal protection in stainless steel
4. Front panel



Colorant Circuits

1.1.2. ELECTRICAL CONTROL PANEL

It is located inside the machine under the suspended stainless steel surface where all main electrical connections of the system are housed. See para. 2.5.1.

2. PARTS REMOVAL AND REPLACEMENT

This chapter shows how to disassemble the MINI MIXER and replace the main components that are subject to possible faults.

2.0. SAFETY REGULATIONS ON MAINTENANCE

2.0.1. AUTHORISED PERSONNEL

The operations described in this chapter must be carried out in dangerous service areas **RESERVED TO TRAINED AND AUTHORISED TECHNICAL PERSONNEL**.

2.0.2. MACHINE SWITCHING OFF

In order to switch off the machine, turn the main switch to its “O” position and disconnect the power cable from the socket.

NOTE: in order to disconnect the machine, the operator must not rely exclusively upon the power switch, but must also unplug the machine power cable.

2.0.3. ACCESS TO THE REPAIR OPERATIONS



THE MACHINE POWER CABLE MUST BE UNPLUGGED FROM THE MAINS BEFORE ACCESSING THE SERVICE AREA AND BEFORE PERFORMING ANY REPLACEMENT/REPAIR OPERATIONS. IT IS ALSO RECOMMENDED TO POSITION THE CABLE SO THAT THE PLUG IS ALWAYS VISIBLE TO THE OPERATOR DURING THE COURSE OF THE MAINTENANCE INTERVENTION.

2.0.4. MACHINE RESTORATION AND START AFTER THE INTERVENTION

Once the repair intervention has been completed:

- **RESTORE ALL THE ELECTRICAL CONNECTIONS**
- **RESTORE ALL THE GROUNDING CONNECTIONS**
- **REINSTALL ALL THE REMOVED PROTECTION DEVICES**
- **PLUG THE MACHINE TO THE MAINS**
- **CLOSE THE DOOR AND PERFORM A FUNCTIONAL CHECK (SEE 4 OF THE OPERATOR MANUAL).**
- **PERFORM A FUNCTIONAL CHECK OF THE SAFETY DEVICES (PARA. 2.0.5)**

ALFA SHALL BEAR NO RESPONSIBILITY FOR ANY MACHINE MALFUNCTIONS OR PROBLEMS THAT MAY ARISE DUE TO THE OMISSION OR INCORRECT EXECUTION OF THE MAINTENANCE OPERATIONS.

2.0.5. CHECKING THE OPERATION OF THE SAFETY DEVICES

In order to ensure trouble-free operation in maximum safety conditions, the door interlock switch must operate properly.

After ordinary maintenance, check that the interlock drive key is on the opening door and that it is fitted correctly by manually opening and closing the door and checking that it fits in the safety micro-switch seat correctly.

To check that the system works well, start the mixer and open the door during the stirring cycle to check that the rotation stops abruptly.

If the machine does not stop, the system may be faulty. In this case, solve the problem and repeat the check.

If the problem persists, switch off the machine and contact the technical service.

2.0.6. WORK EQUIPMENT

Allen wrench, 2.5 – 3 – 4 – 5 mm



Open adjustable wrench, 13 mm



PH1 cross head screwdriver



PH1 flat head screwdriver



Cutting nippers



Plastic tie, 3.6 mm



2.0.7. PRODUCT DISPOSAL

During maintenance or repair, electric parts, other mechanical parts or colorants might have to be replaced.

Electrical components must be disposed of at specific recovery points, in accordance with applicable regulations.

Colorants must be collected in suitable tanks to be treated and disposed of in a suitable way.

It is forbidden to release the products in the environment or in the public sewers.

2.1. EXTERNAL PANEL REMOVAL

To access internal electric and mechanical parts, remove the external and internal covers of the machine as described in this paragraph.

Before starting the removal procedure, switch off the machine (see para. 2.0.2).

2.1.1. FRONT PANEL REMOVAL

- Loosen the 4 countersunk head screws (1) on the upper part of the cover with a 2 mm Allen wrench.



- Loosen the 5 button head screws (2) on the lower part of the cover with a 2.5 mm Allen wrench.

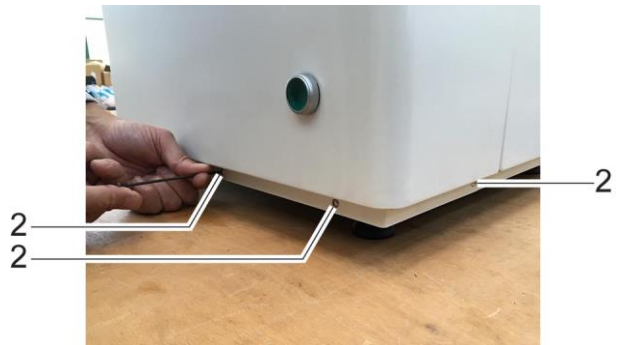

Keep toothed washers, if any.

- Slide the panel out making sure to widen the lateral supports to disengage them.

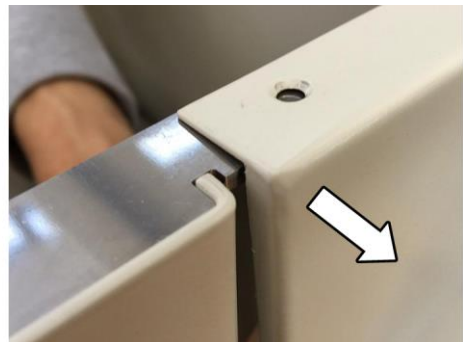

- Disconnect the START/STOP button contact, then completely remove the front panel.



Panel reassembly

To reassemble the panel follow the removal steps in the reverse order.

Note: First tighten the upper countersunk screws and then the lower button head screws.

Remember to reposition the toothed washers where needed.

2.1.2. REAR PANEL REMOVAL

- Remove the upper door by loosening the 4 retaining screws (1) - two per side - with a 3 mm Allen wrench



Proceed as with the front panel:

- Loosen the 4 countersunk head screws (2) on the upper part of the cover with a 2 mm Allen wrench.
- Loosen the 5 button head screws (3) on the lower part of the cover with a 2.5 mm Allen wrench.

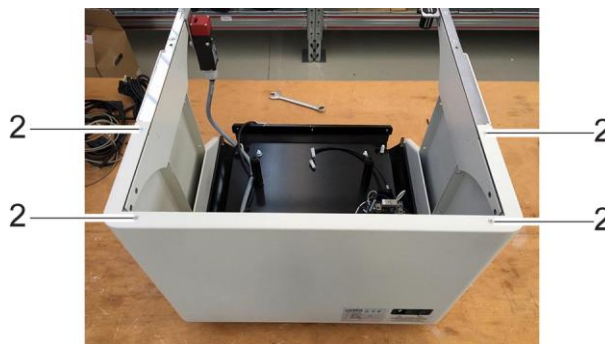

Keep toothed washers, if any.



Slide the panel out making sure to widen the lateral supports to disengage them.

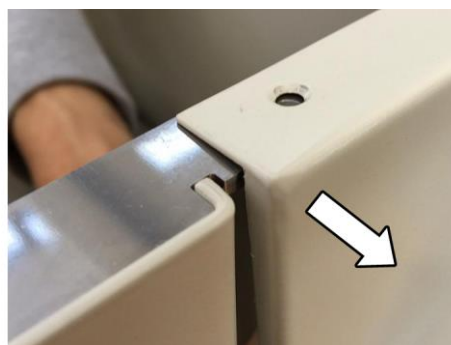

Panel reassembly:

To reassemble the panel follow the removal steps in the reverse order.

Note: the panel must overlap the lateral support panel. Remember to reposition the toothed washers where needed.

Note: First tighten the upper countersunk screws and then the lower button head screws.



2.2. BELT AND STIRRING UNIT REPLACEMENT

To replace the rotating unit drive belt proceed as follows.

The drive belt can be replaced without having to remove the front and rear external panels.

- Open the upper door;
- Loosen the 4 rotating plate retaining screws (1) with a 4 mm Allen wrench;
- Remove the stirring unit.



- Position the new drive belt as shown in figure.



- Keeping the belt well taut, lower the unit into the seat by inserting the free part of the belt into the pulley below.
- Then position the plate in such a way as to centre the rotating shaft pin.
- Tighten the 4 previously removed screws using a medium strength threadlocker.



2.3. REMOVAL OF THE STAINLESS STEEL INTERNAL PROTECTION PLATE

To access the electric parts below (DC motor, control board, power supply unit, relay, fuses, etc.) the internal stainless steel plate must be removed, as described in this paragraph.

- Remove the stirring unit as described in paragraph 2.2 and the front panel as described in para. 2.1.1.
- Then loosen the 4 hexagon head screws using a 13 mm wrench.

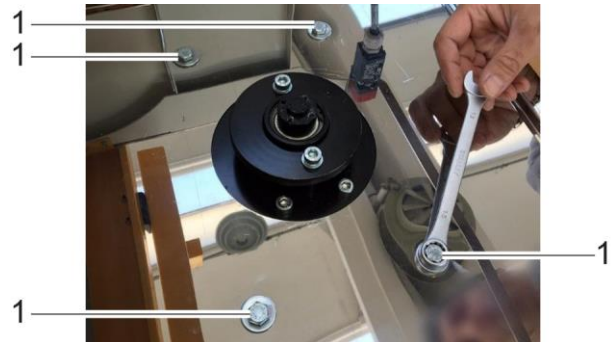

- Raise the stainless steel panel and slide it out by tilting it to its side.



Reassembly of the stainless steel internal plate:

- To reassemble the panel follow the removal steps in the reverse order.
- Reposition the micro-switch wiring fairlead into its seat.



2.4. DC MOTOR AND/OR BEARINGS REPLACEMENT

To replace the motor proceed as described below.

Remove the front panel as described in para. 2.1.1.
 Remove the stirring unit as described in paragraph 2.2.
 Remove the internal stainless steel plate as described in paragraph 2.3.

- Disconnect motor wiring (1) and lift the upper minimixer plate (2), placed on the 4 support stud bolts.

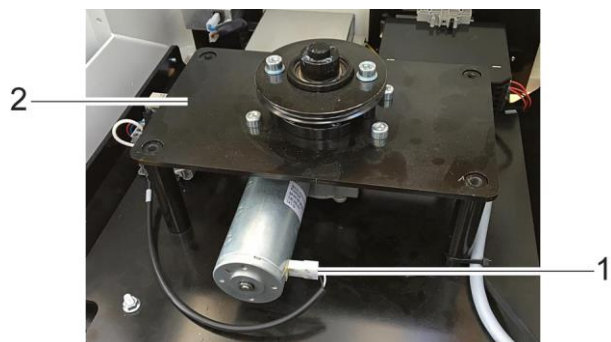

- Then remove the 4 screws (3) with a 6 mm Allen wrench to free the motor support flange below (4).
- Loosen the 4 countersunk screws (5) that join the flange to the motor to free the motor and allow its replacement.
- For further details and spare part codes refer to the exploded view diagrams in chapter 6.

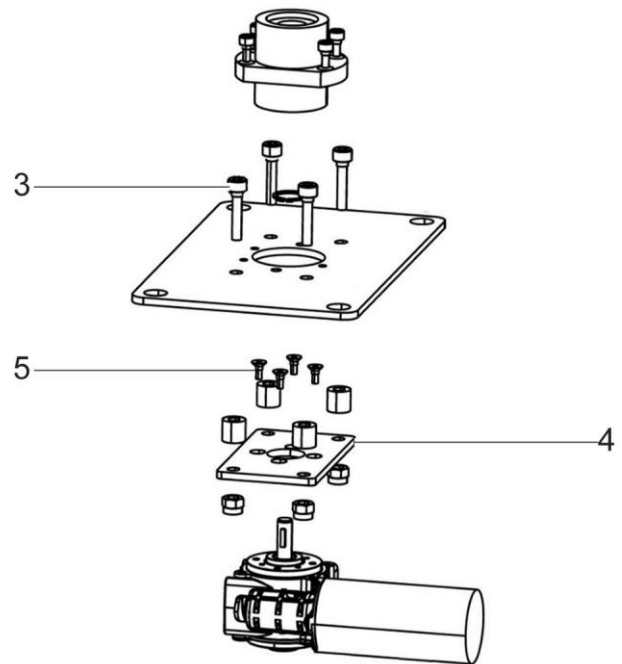

- If the motor shaft does not easily come off the seat, remove the cap on the central pin head with a flat head screwdriver, insert an adequately sized tool until it touches the shaft below, and then gently tap the tool with a hammer.

2.5. VIBRATION DAMPER REPLACEMENT

Between the support stud bolt plate and the Mixer base there are rubber vibration damper spacers (6).

- To replace a vibration damper remove the suspended plate (7) by loosening the 4 flanged nuts on the surface.
- Then remove the nut that fastens the vibration damper to the lower base.
- Fit the spare vibration damper by following the removal steps in the reverse order.

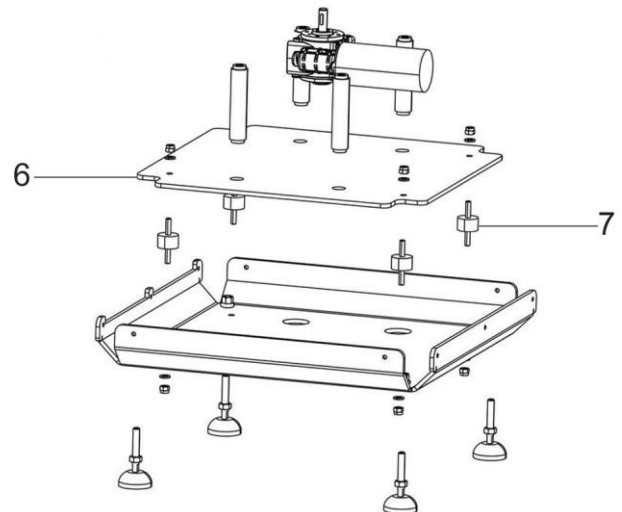

3. ELECTRIC REPAIRING OPERATIONS

3.1. DIAGNOSIS AND ELECTRONIC PART DESCRIPTION

3.1.1. SCCB BOARD

The machine is fitted with a SCCB board that controls functions and work cycles.

The board is powered at 24Vdc and checks sensor inputs (START/STOP button, safety micro-switch) and integrates the control drivers of the peripherals (DC motor, relay, lamp).

The board generates the necessary on-board service voltage. To facilitate the diagnosis, each power supply features a status LED (on = power connected):

- DL11 = 3.3V
- DL12 = 5V
- DL10 = 15V

Likewise, the DC MOT (CN13) and EV (CN11) outputs have a status LED that indicates when they are powered.

If the DC MOT line is inactive, check the protection fuse status (see para. 3.3.5).

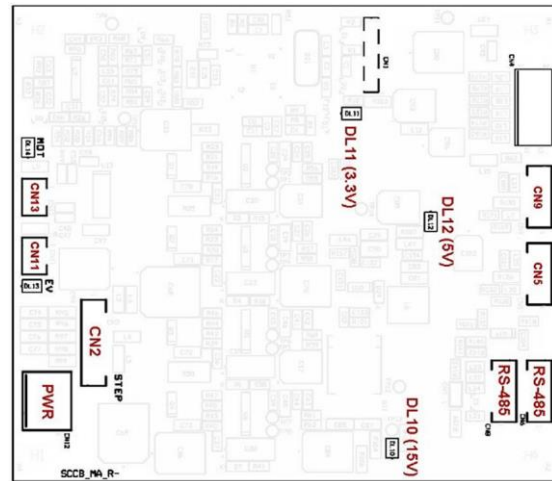

Following is a list of the connections of each SCCB board. For further details refer to the wiring diagram in chapter 7.

CN12	24V DC power supply
CN11	Lamp
CN13	DC motor power supply (via relay)
CN2	Relay tripping
CN4	Timer programming
CN9	Door safety micro-switch control
CN5	START/STOP button

3.2. CHECKING AND REPLACING THE NETWORK FUSES

In case of mains malfunction or problems, the safety fuses could cut out the power supply.

Fuses are located in the fuse holder built into the socket with switch on the back panel (see para. 1.1.).

To replace the blown fuse, open the fuse holder using a flat screwdriver in the suitable slot to prise it open, then remove the fuse holder and the fuses and replace them with new components of the same type.

	<p>USE ONLY FUSES OF THE SAME TYPE AND THE NOMINAL RATING SHOWN IN THE PRODUCT LABEL.</p> <p>Fuse requirements: EU - IEC 60127 Approval US - UL248-1 and UL248-14 Approval</p>
--	--

3.3. REPLACEMENT OF ELECTRIC PARTS

Under the internal stainless steel protection (see para. 1.1.1) there are main electric mixer components. To access the electric parts and run maintenance or repair work, proceed as follows.

- Remove the rear panel as described in para. 2.1.2.
- Remove the stirring unit as described in paragraph 2.2.
- Remove the internal stainless steel plate as described in paragraph 2.3.

3.3.1. DESCRIPTION OF ELECTRIC PARTS

Under the internal stainless steel panel the following components are present:

1. 100-240Vac, 24Vdc power supply unit;
2. Motor control SCCB board (with stainless steel protection);
3. 2.7 Ohm 25W braking resistance;
4. 1.5 Ohm 25W Emergency braking resistance;
5. EMI filter with mains fuse holder;
6. Motor protection fuse;
7. Braking control relay

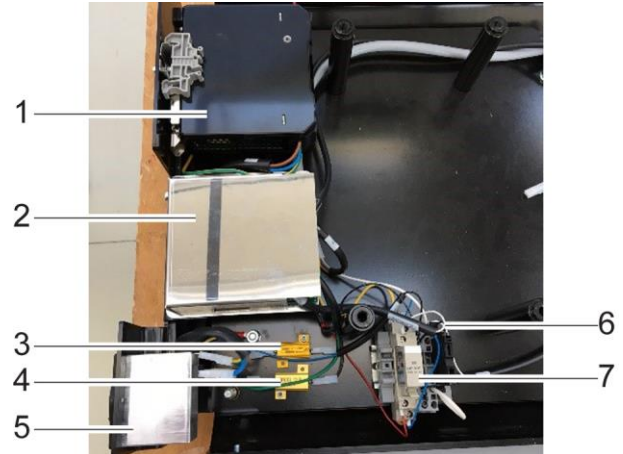

3.3.2. REPLACING THE POWER SUPPLY UNIT

- make sure the machine is disconnected from the power supply as described in para. 2.0.2.
- Disconnect the wiring between the power supply unit to be replaced and the rest of the machine.
- Remove the power supply unit by fitting a flat screwdriver in the suitable retaining tab (8) and remove the unit from the DIN rail.

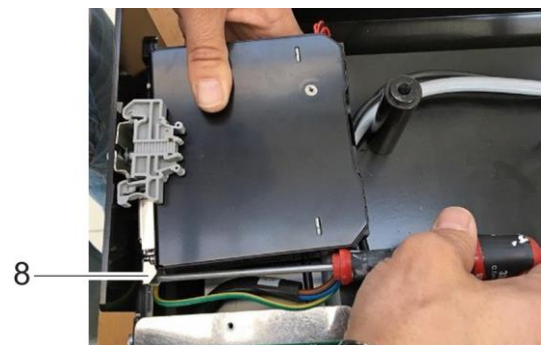

- Fit the new power supply unit manually on the DIN bar.
- Reconnect the power supply unit to the wiring according to the attached wiring diagram.

WARNING: use only genuine spare parts supplied by the manufacturer.

3.3.3. SCCB CONTROL BOARD REPLACEMENT

- Loosen the retaining screw from the stainless steel protection (2) under which the board is placed.
- Disconnect the power supply and signal cables from the board.
- Remove the board by releasing it from the supports (9) on its corners.
- Insert a new board on the supports having care not to damage its components.

WARNING: Use a board already programmed with the function of the replaced board. To reprogramme the board refer to chapter 4.



- Restore the previously disconnected connections according to the wiring diagram.

3.3.4. RELAY AND BRAKING RESISTANCE REPLACEMENT

- To replace the relay, remove the damaged relay from the relay holding base by pressing the release lever (1).
- Position the new relay on the base and press it downwards until it fits in its seat.
- To replace the resistors (2), disconnect the faston connectors and loosen the retaining screws of the resistor that needs to be replaced with a 2 mm Allen wrench.
- Fasten the new resistor to the surface using the previously removed screws and reconnect the faston connectors by following the wiring diagram attached.

WARNING: use only genuine spare parts supplied by the manufacturer.

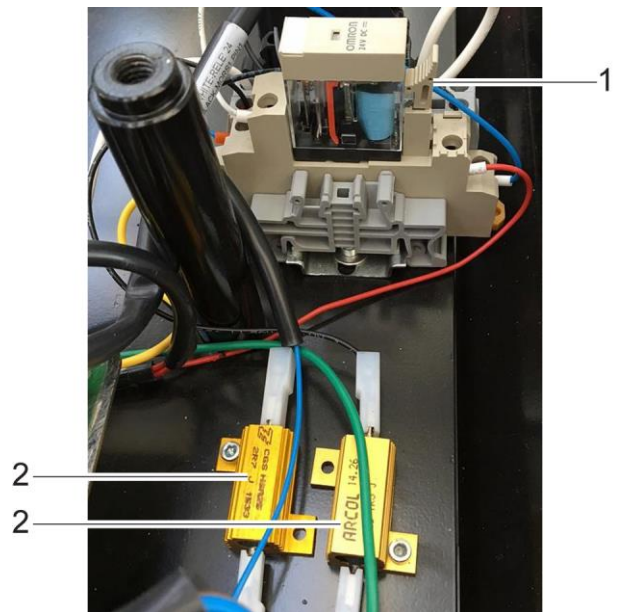

3.3.5. MOTOR PROTECTION FUSE REPLACEMENT

In case of malfunction or problems, the safety fuse could cut out the power supply circuit of the motor. Replace as described.

- Open the side door of the fuse holder (3) until it is possible to manually remove the damaged fuse.
- Insert the new fuse in the fuse holder.
- Close the fuse holder by slightly pressing on it.
- Check with a tester that there is continuity between fuse holder input and output circuits.

WARNING: use only fuse of the same type and with the same nominal rating specified by the manufacturer.

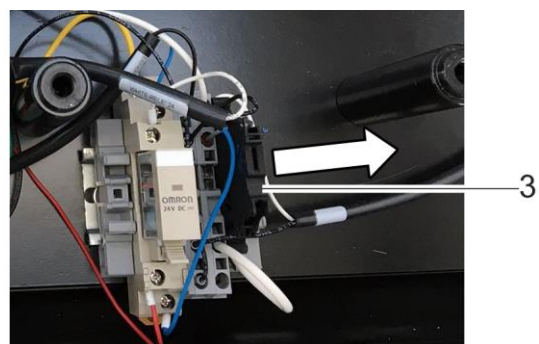

4. PROGRAMMING THE ELECTRONIC BOARDS

4.1. PROGRAMMING DEVICES

Each SCCB board must have the dedicated firmware. For the SCCB boards, the firmware depends on the group to control. The Mini Mixer features only one equipment to be checked and therefore one firmware.

To programme the boards, use a suitable USB programmer (1) and the MPLAB IDE programming software.

If you do not have the suitable programmer, contact the Alfa technical service.

The programmer uses a USB cable (2) for the connection to the PC.

It could be useful to use an extension (3) to connect the programmer to the boards positioned in points that are hard to reach.

NOTE: The boards can be programmed both on the machine and on the bench. To programme the boards they must be powered by means of CN12 connector. If you use the previously programmed boards for other functions it is recommendable to disconnect the RS-485 serial connectors before powering the machine.

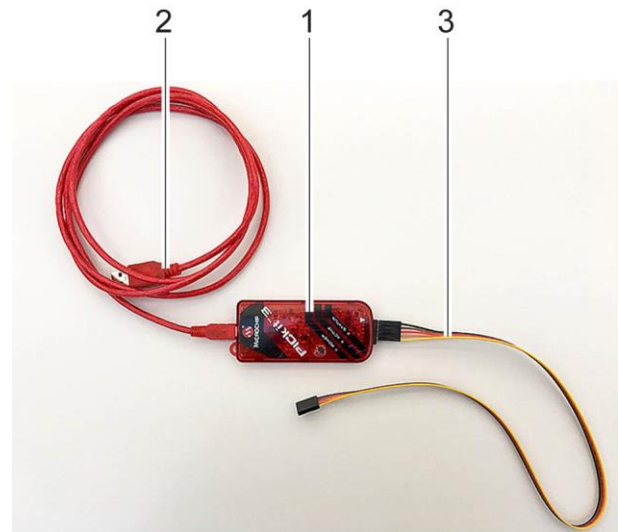

4.2. INSTALLING THE MPLAB IDE SOFTWARE

The MPLAB IDE programming software can be downloaded from the reserved area of the website www.alfadispenser.com or from the download area of the website <http://www.microchip.com>. The software can be installed on a Windows, Linux or Mac PC.

4.3. PROGRAMMING WORKSPACE

To write the firmware it is necessary have a programming workspace to upload in the MPLAB IDE software as better described below.

To program the Mini Mixer SCCG board upload the workspace "Actuators_release_PICKIT3.mcw" (4). Other workspaces can be used to program different boards.

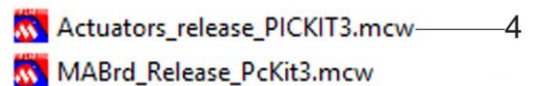

4.4. PROGRAMMING THE SCCB BOARD

4.4.1. FIRMWARE AND WORKSPACE DOWNLOAD

Download the workspace and the last available firmware version from the Alfa website reserved area, or contact the Alfa technical service to receive the firmware. If you do not have the credentials to access the reserved area, contact the Alfa technical service.

SCCB: there is only one firmware version for the Mini Mixer board:

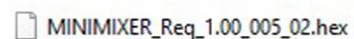

- Color Tester MAB board firmware

WARNING: CAREFULLY READ THE RELEASE NOTE TO CHECK THE FIRMWARE VERSION COMPATIBILITY

4.4.2. PROGRAMMING THE MINI MIXER SCCB BOARD

Connect the USB programmer, if necessary use an extension, to CN1 connector of the board to be programmed.

WARNING: Check that pin 1 of the programmer (4) is connected to pin 1 of CN1 connector (5)!

Power the board by connecting the CN12 connector (6) to the machine.

WARNING: do not connect the CN6 and CN8 connectors of the RS-485 communication to avoid problems linked with possible address conflicts.

Launch the MPLAB IDE software

Access to “File – Open workspace...” and select the workspace of the board to program (SCCB, see para. 4.3), then press Open.

If message “No PICkit 3 Connected” is displayed, it means that the programmer is not connected correctly.

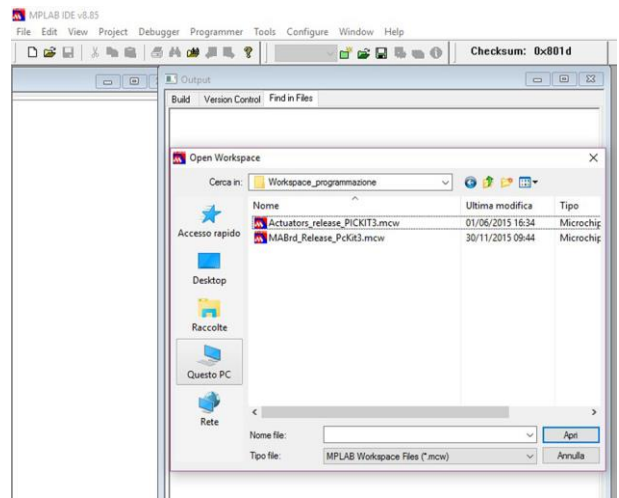
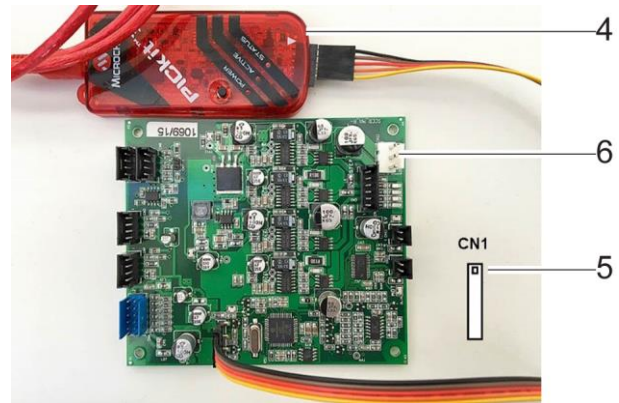

When the programmer is correctly connected and detected, the software will show the message “PICkit 3 detected”.

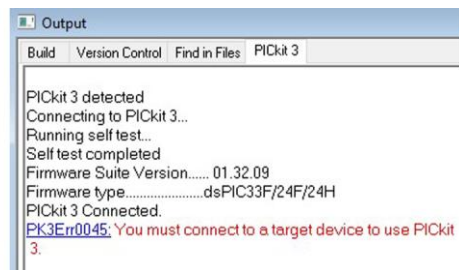

When connecting the board to the programmer and powering it, the software shows the message “Target Detected”.

besides the DEVICE ID of the connected board.

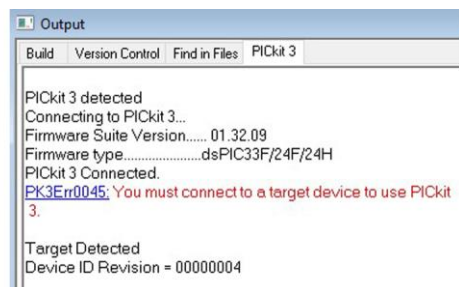

WARNING: If you upload an SCCB Workspace and connect a MAB board (or vice versa), the software will show the error “Target device ID does not match expected Device ID”.



When everything is ready, programme the board in “File – Import...” and select the suitable firmware version.

Select the suitable firmware version and select “Open”.

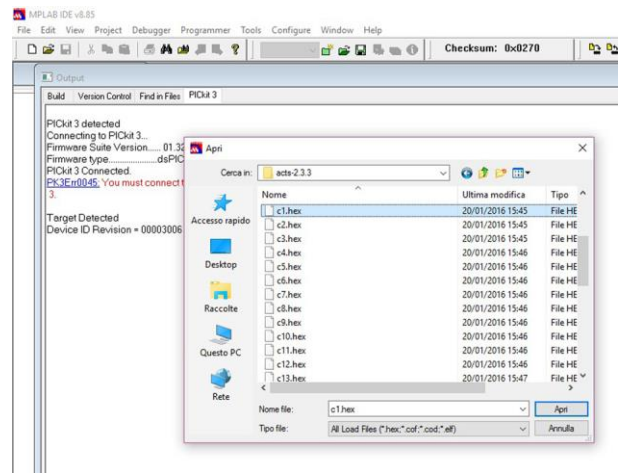

If the operation is completed successfully, the display will show the message “Loaded....”

Select “Program” in the “Programmer” menu to start the board programming.

At the end of the operation, the display will show the message “Programming/Verify complete”.

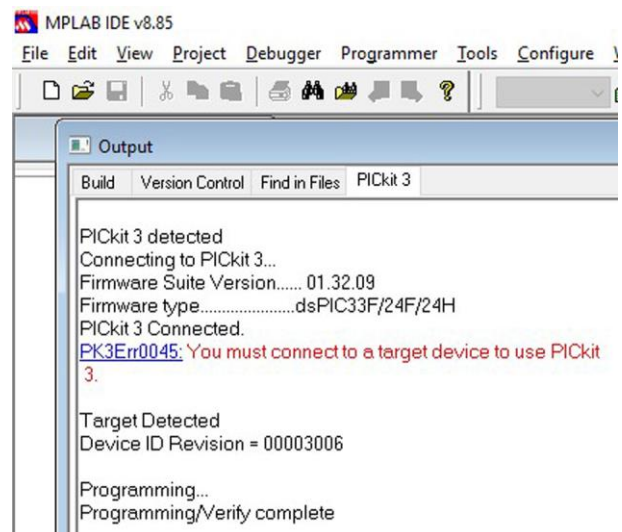
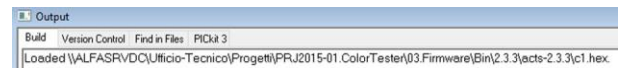

Now it is possible to disconnect the power supply and the programmer.

The board is ready to be used on the machine.

WARNING: Before programming a new board, always make sure the loaded Workspace is the correct one. If this is not the case, go back to the “File – Open workspace...” menu and upload the new workspace.

5. PROGRAMMING STIRRING TIME

5.1. PROGRAMMING INPUT

The SCCB board has a connector (CN4) that can be wired to program various stirring cycle times.

Possible programs are as follows:

- Cycle duration: 30 SECONDS (default)



- Cycle duration: 45 SECONDS (s.c. pin 1-7)



- Cycle duration: 60 SECONDS (s.c. pin 3-7)



- Cycle duration: 90 SECONDS (s.c. pin 5-7)



6. MECHANICAL DRAWINGS AND SPARE PARTS LIST

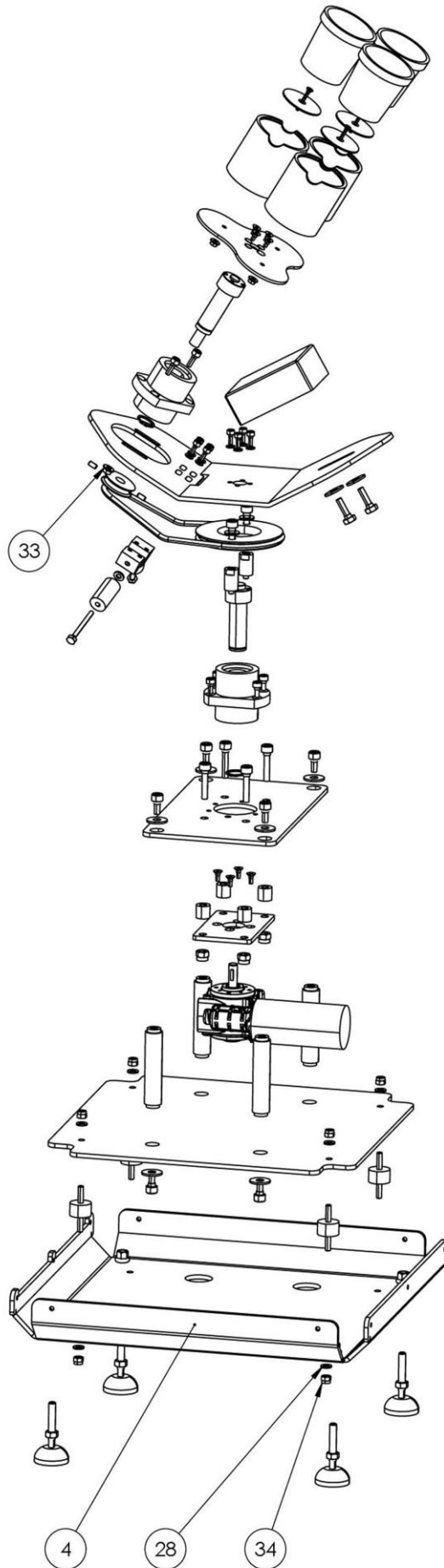

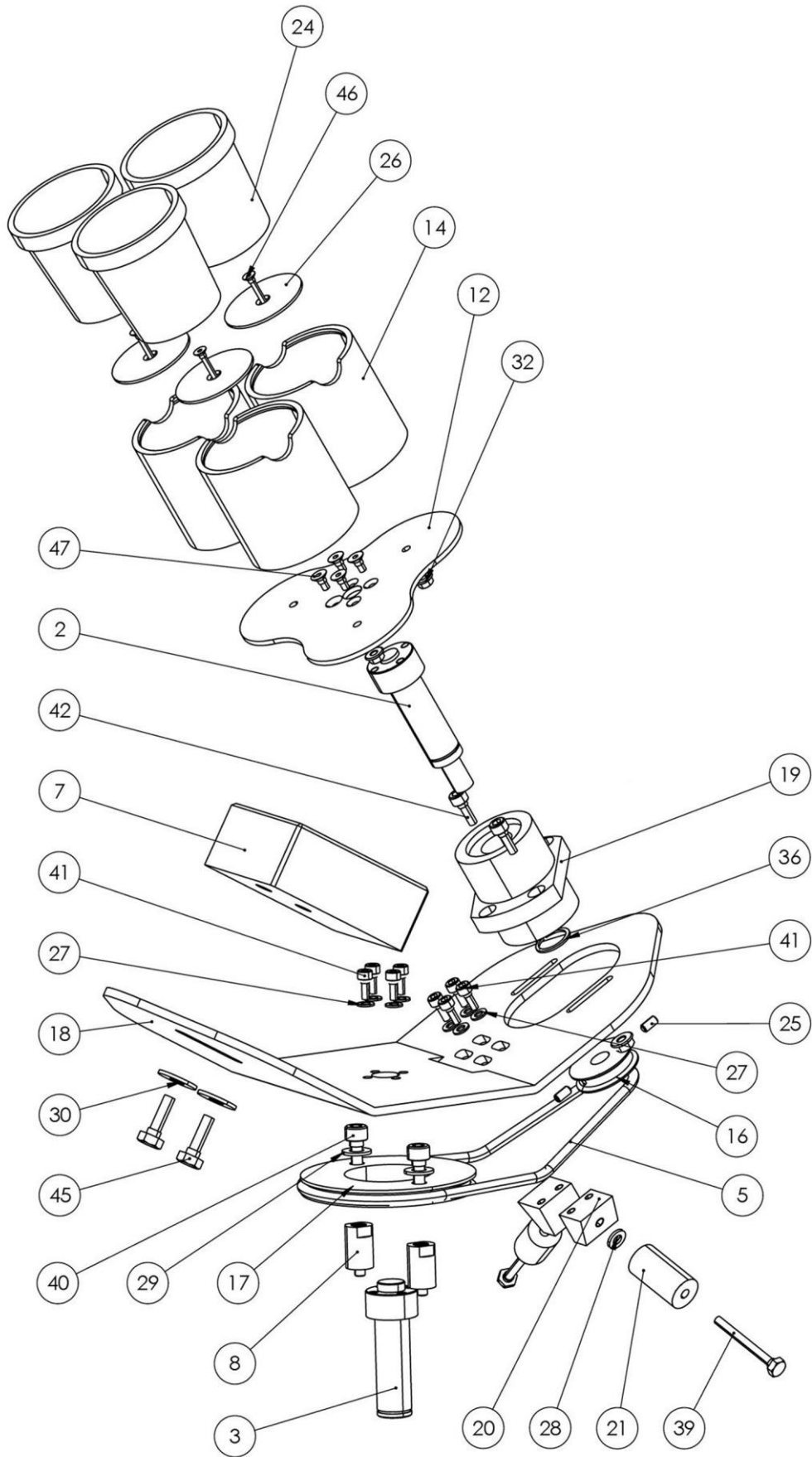

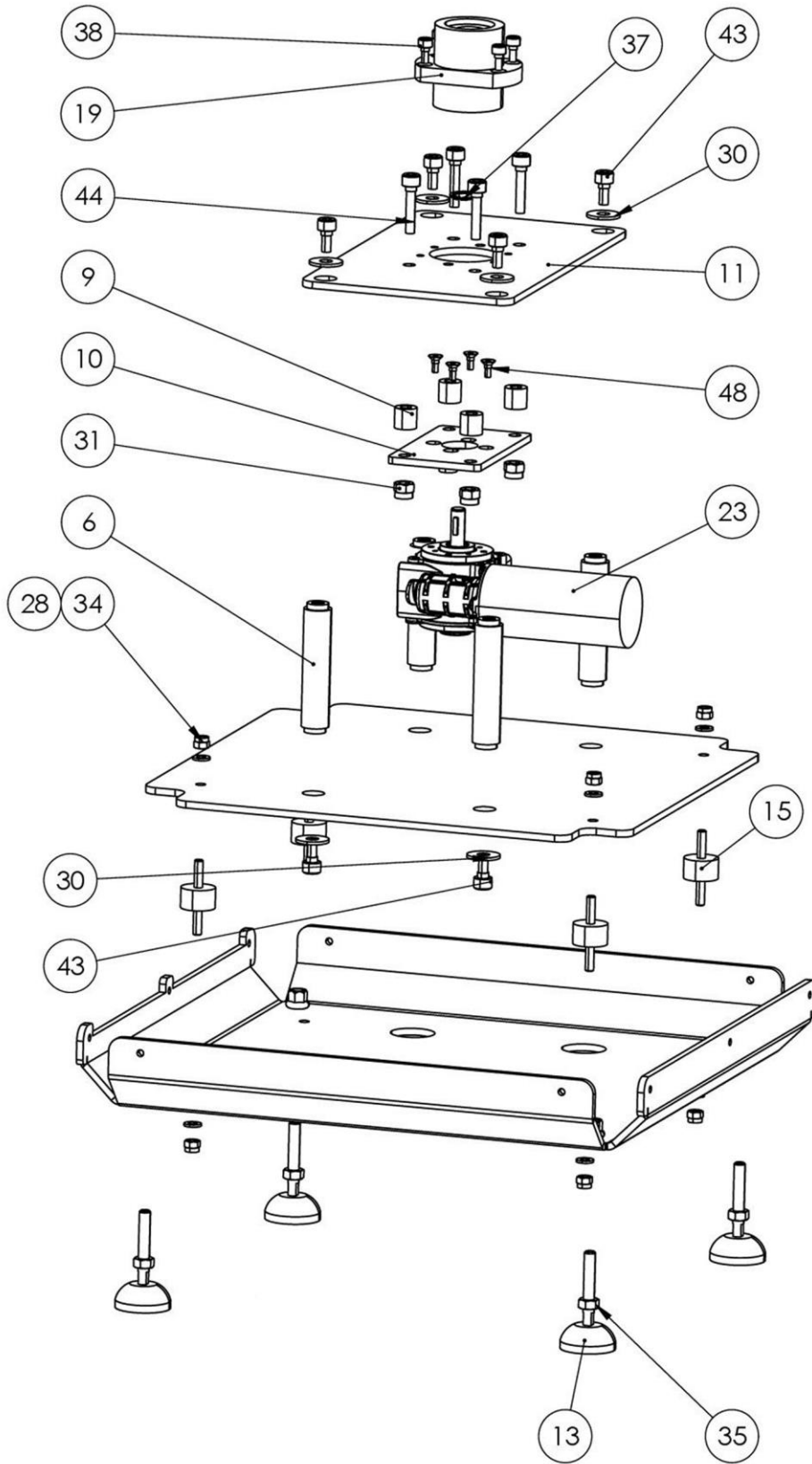

48		Hex. socket countersunk head M5X12 SCREW	4
47		Hex. socket countersunk head M5X10 SCREW	4
46		Hex. socket countersunk head M4X30 SCREW	3
45		Hex. head M8X25 SCREW	2
44		Hex. socket head cap M8X35 SCREW	4
43		Hex. socket head cap M8X16 SCREW	8
42		Hex. socket head cap M6X16 SCREW	2
41		Hex. socket head cap M5X12 SCREW	8
40		Hex. socket head cap M8X20 SCREW	2
39		Hex. head M6X50 SCREW	2
38		Hex. socket head cap M6X12 SCREW	4
37		SHAFT CIRCLIP 20	1
36		SHAFT CIRCLIP 19	1
35		M8 NUT	4
34		SELF-LOCKING NUT M6	8
33		M6 FLANGED NUT	2
32		M5 FLANGED NUT	3
31		SELF-LOCKING NUT M8	4
30		WASHER ID 8 OD 24	10
29		WASHER Ø 8	2
28		WASHER Ø 6	10
27		WASHER Ø 5	8
26		D5 WASHER OD 50	3
25		M5 DOWEL	2
24		60 ML GLASS	3
23		GEARMOTOR KIT	1
22	8LB0183981		4
21	301000711	MMX BELT TENSIONER	2
20	301000709	MMX BELT TENSIONER SUPPORT	2
19	301000385	MMX FLANGED SUPPORT	1
18	301000684	MMX STIRRING BRACKET	1
17	301000708	DRIVING PULLEY	1
16	301000707	DRIVEN PULLEY	1
15	300300727	PFISTER PUFFER	4
14	301000692	MMX PACKAGE HOLDER	3
13	300300782	PA – D40 H68 M8 BASE ARTICULATED FOOT	4
12	301000687	MMX PACKAGE HOLDER PLATE	1
11	301000683	MMX UPPER PLATE	1
10	301000691	MMX MOTOR FLANGE	1
9	301000693	MMX PIPE SPACER	4
8	301000689	MMX SPACER	2
7	301000688	MX COUNTERWEIGHT	1
6	301000682	MMX COLUMN	4
5	300300781	D6.3 ROUND BELT - TRC1741 VOLTA	1
4	300300713	MMX SUPPORT BASE - LPXAU120	1
3	301000690	MMX MOTOR SHAFT	1
2	30100686	MMX MOBILE SHAFT	1
1	301000681	MMX BASE	1
POS.	CODE	DESCRIPTION	Qty

7. CONNECTION DIAGRAMS

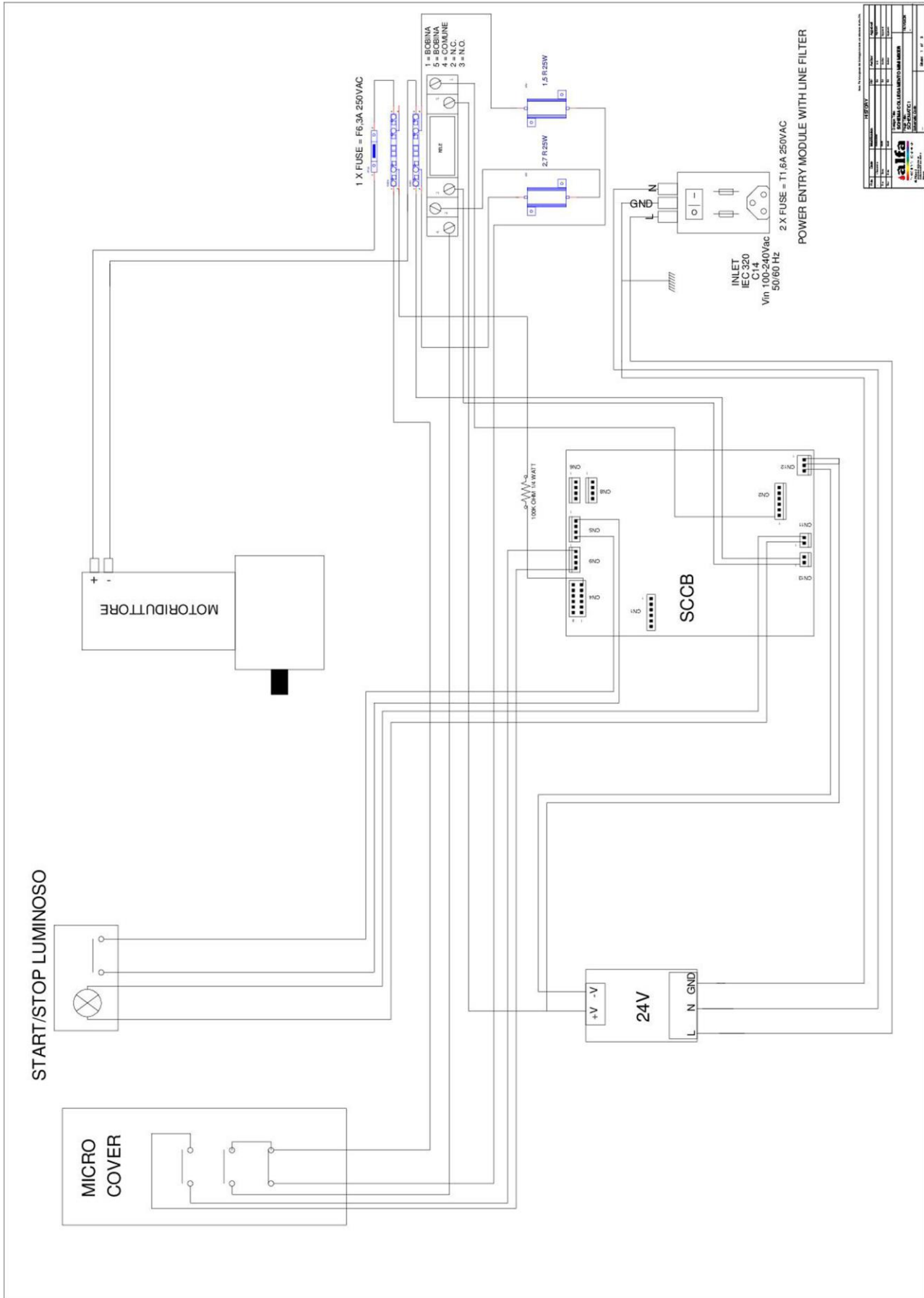

Table 3: Product Information

Model	Year	Version
MINI MIXER	2010	1.0

Table 4: Alfa S.p.A. Details

Field	Value
ALFA S.p.A.	Via S. Felice, 10 - 40027 BOLOGNA (BO) - ITALIA
TELEFONO	051 26721
FAX	051 26722
TELEGRAMMI	ALFA I
TELEFONO	051 26721
FAX	051 26722
TELEGRAMMI	ALFA I

Table 5: Document Information

Field	Value
Model	MINI MIXER
Year	2010
Version	1.0
Page	1 of 3



Alfa Srl

Headquarters:

Via Caduti di Ustica, 28

I-40012 – Calderara di Reno (BO), Italy

Tel. +39 (0)51 0828494

Fax +39 (0)51 0823283

Registered Office:

Via Santa Chiara, 2

I- 40137 – Bologna, Italy

VAT: IT-03364471205 – REA BO: 513367

Shared Capital € 500.000,00 f.p.

Website: www.alfadispenser.com

E-mail: info@alfadispenser.com

Timbro rivenditore

Sales Mark

